

# Instrument Transformers

Energizing the World since 1979

# Sustainability



# Table of content

Our Philosophy	4
Product Overview	5
CEI - UNEL CT	6
Brick Type CT	10
DIN CT	12
Ring Current CT	15
CEI - UNEL Phase to Phase VT	16
CEI - UNEL Phase to Ground VT	18
DIN Phase to Phase VT	20
DIN Phase to Ground VT	22
Fuse - Holder Phase to Ground VT	24

# Our Philosophy

Tesar transforms the Wind, the Sun and the Water in renewable Energy.

Tesar, in order to improve its redditivity and competitiveness, has in force a Quality Operating System UNI EN ISO 9001. In this way, all the activities related to the proper execution of the jobs, are carried out in the full respect of the wealth safeguard as well as of the ambient.



Highest Quality

# Product Overview



**CEI-UNEL CT**



**Brick Type CT**



**DIN CT**



**Ring Current CT**



**CEI-UNEL Phase to Phase VT**



**CEI-UNEL Phase to Ground VT**



**DIN Phase to Phase VT /  
Phase to Ground VT**



**Fuse-Holder Phase to  
Ground VT**



# CEI-UNEL CT

## General Characteristics

### General Characteristics

- Dimensions according to CEI-UNEL 21009 std
- Manufactured and tested acc. to IEC 61869-1/2
- Rated Insulation level up to 36 kV
- Frequency 50 or 60 Hz
- Rated primary current (Ipr)
  - Single primary current from 5 to 2500 A
  - Double primary current
    - Up to 2 x 300 A change on prim. winding
    - Up to 2 x 1250 A change on sec. winding
- Rated secondary current (I<sub>sr</sub>) 5 A
- Short-time current (I<sub>th</sub>) up to 40 kA x 1s
- Rated dynamic current (I<sub>dyn</sub>) 2.5 x I<sub>th</sub>

- Number of secondary 1 or 2
- Security factor  $\leq 5$  or  $\leq 10$
- Indoor installation
- Accuracy class for measure: 0,5 - 0,5s - 0,2 - 0,2s
- Accuracy class for protection: 5P10 - 5P20 - 5P30

### On request

- Third secondary
- Rated secondary current 1A
- Sealable terminal cover
- Capacitive tap

### Primary Terminals

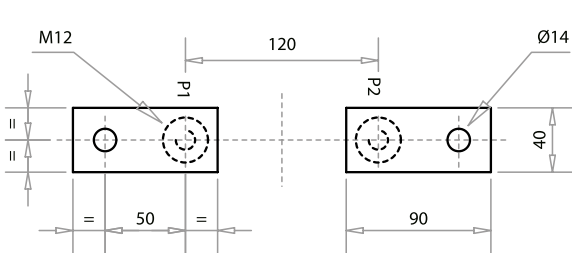

5 - 600 A

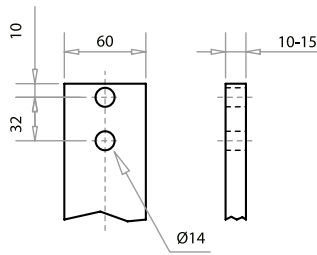

800 - 1200 A

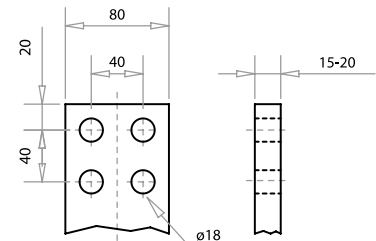

1500 - 2500 A

### Double Primary Current

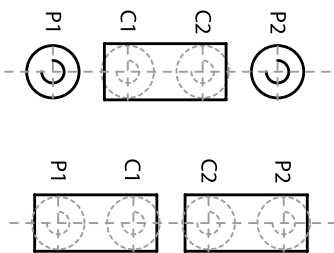

$\leq 2 \times 300$  A

Low Ratio

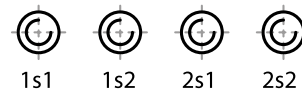

High Ratio

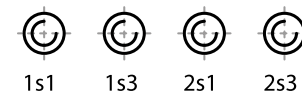

$\leq 2 \times 1250$  A

$\leq 2 \times 1250$  A

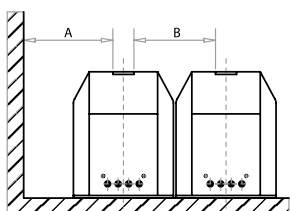

Minimum suggested assembly distances

	12 kV	24 kV	36 kV
A [mm]	120	220	320
B [mm]	120	220	320

According to IEC / CEI EN 6007-1

# 12 kV

## Overall Dimensions

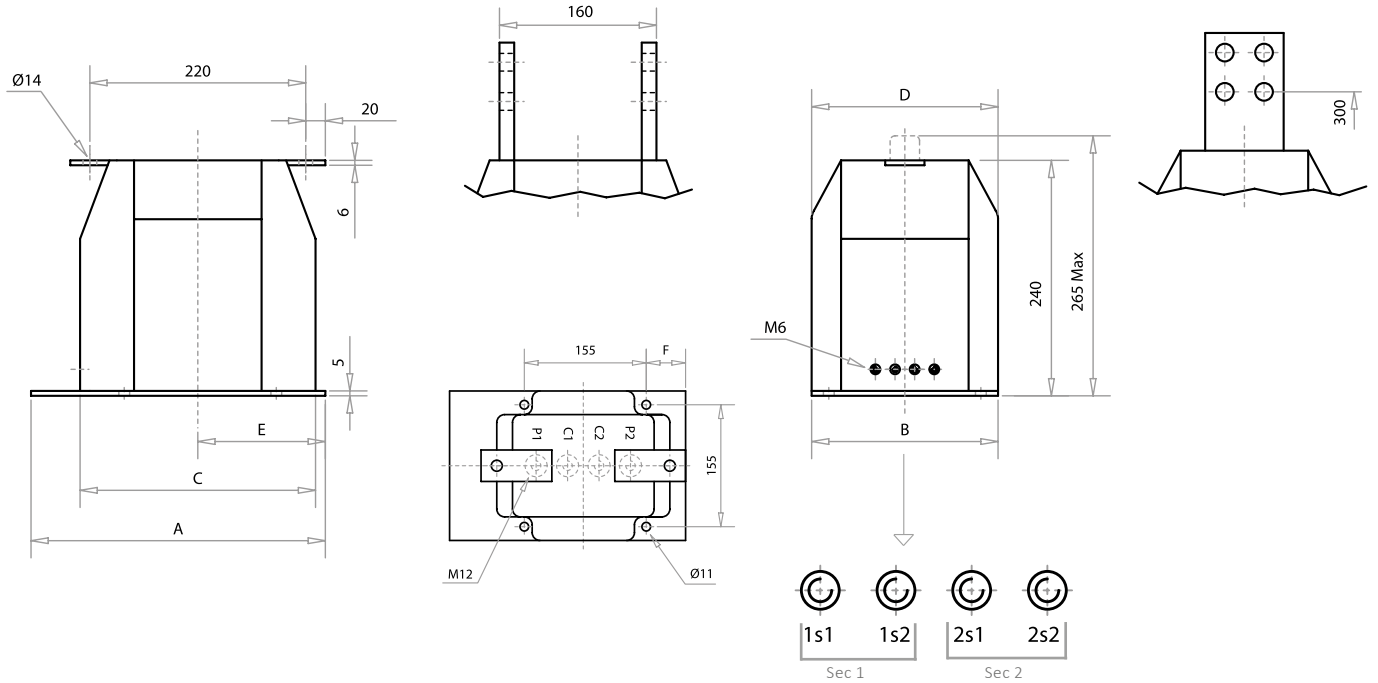

AA11



AA12



AA13



AA14

Type	Ip Max [A]	Max. N° sec.	Dimensions [mm]						Weight [kg]
			A	B	C	D	E	F	
AA11	600	1	250	180	200	145	105	28	~14
AA12	600	2	250	180	200	175	105	28	~16
AA13	1200	2	300	190	220	190	130	50	~23
AA14	2500	3	300	190	240	190	130	50	~25

# 24 kV

## Overall Dimensions

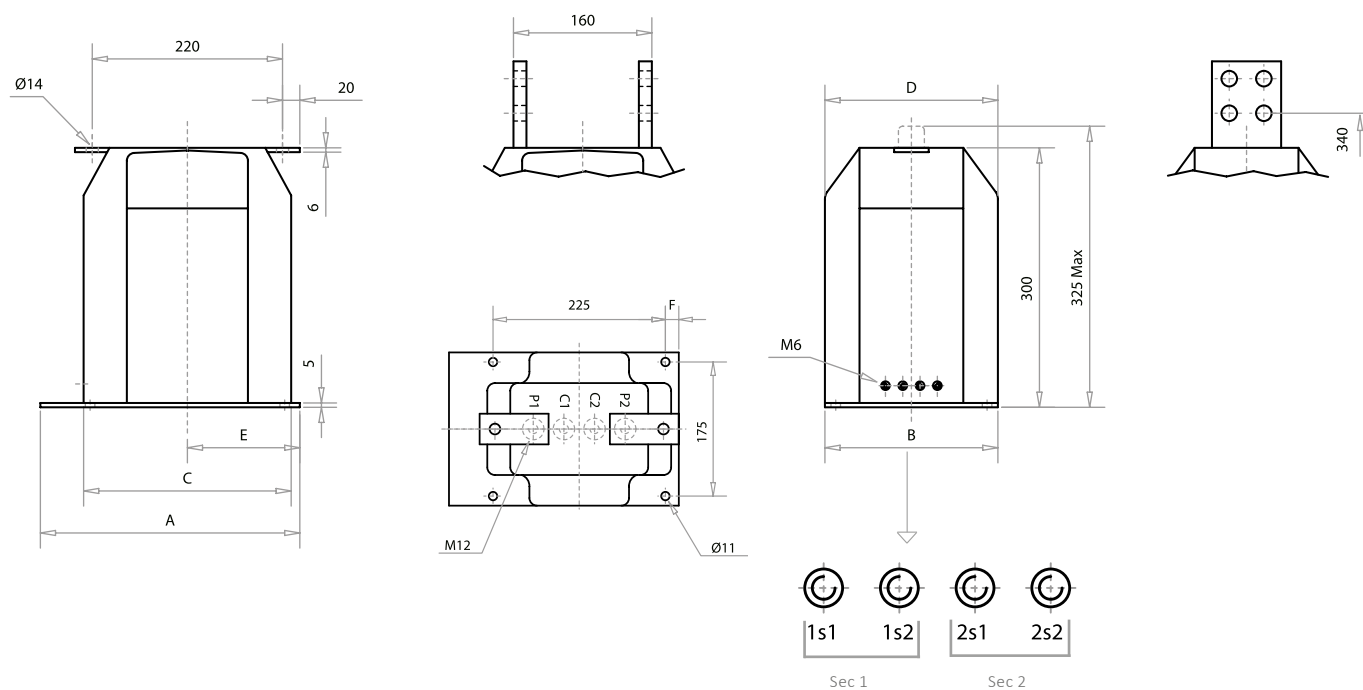

AB11



AB12



AB13



AB16

Type	Ip Max [A]	Max. N° sec.	Dimensions [mm]						Weight [kg]
			A	B	C	D	E	F	
AB11	600	1	300	200	200	150	130	17.5	~16
AB12	600	2	300	200	200	175	130	17.5	~18
AB13	1000	2	300	200	220	200	130	17.5	~25
AB16	2500	3	300	200	240	200	130	17.5	~28



# 36 kV

## Overall Dimensions

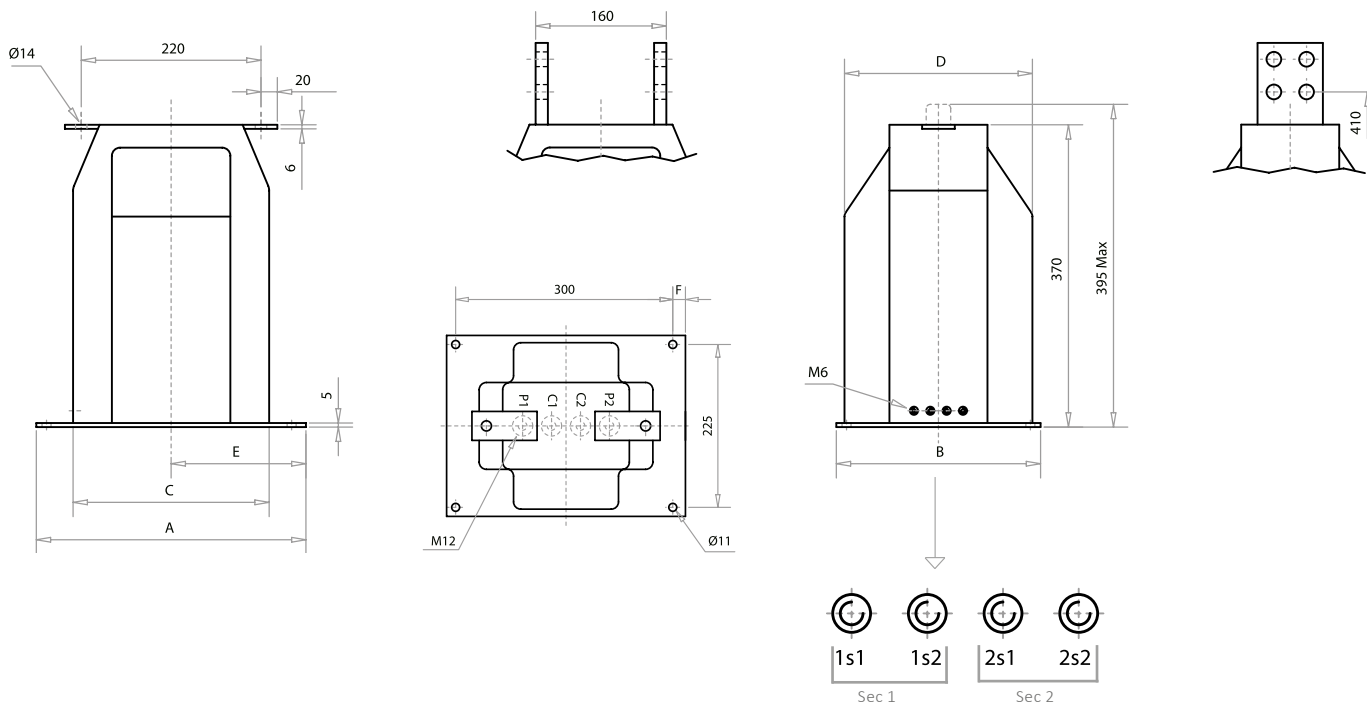

AC10



AC12

Type	Ip Max [A]	Max. N° sec.	Dimensions [mm]						Weight [kg]
			A	B	C	D	E	F	
AC10	600	2	280	210	240	210	140	27.5	~30
AC12	2500	3	330	250	240	230	165	17.5	~30

# BRICK Type CT

## General Characteristics

### General Characteristics

- Compact type suitable for METAL - CLAD switchboards
- Manufactured and tested acc. to IEC 61869-1/2
- Rated Insulation level up to 24 kV
- Frequency 50 or 60 Hz
- Rated primary current ( $I_{pr}$ )
  - Single primary current from 5 to 1250 A
  - Double primary current
    - Up to 2 x 300 A change on prim. winding
    - Up to 2 x 600 A change on sec. winding
- Rated secondary current ( $I_{sr}$ ) 5 A
- Short-time current ( $I_{th}$ ) up to 40 kA x 1s
- Rated dynamic current ( $I_{dyn}$ ) 2.5 x  $I_{th}$
- Number of secondary 1 or 2

- Security factor  $\leq 5$  or  $\leq 10$
- Indoor installation
- Accuracy class for measure: 0,5 - 0,5s - 0,2 - 0,2s
- Accuracy class for protection: 5P10 - 5P20 - 5P30

### On Request

- Third secondary
- Rated secondary current 1A
- Sealable terminal cover
- Capacitive tap

### Primary Terminals

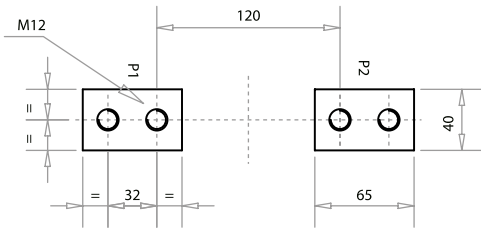

5 - 1250 A

### Double Primary Current

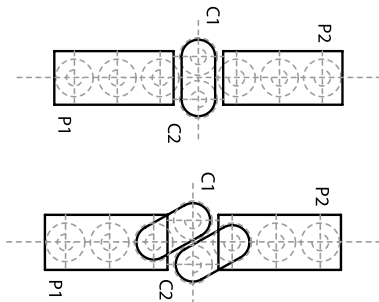

$\leq 2 \times 300$  A

Low Ratio

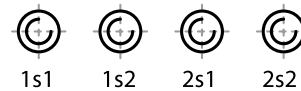

High Ratio

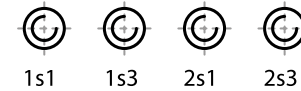

$\leq 2 \times 600$  A

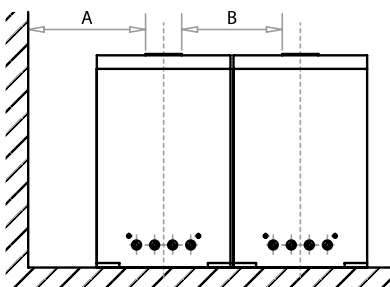

Minimum suggested assembly distances

	24 kV
A [mm]	220
B [mm]	220

According to IEC / CEI EN 6007-1

# 12 kV / 24 kV

## Overall Dimensions

### With metallic supports

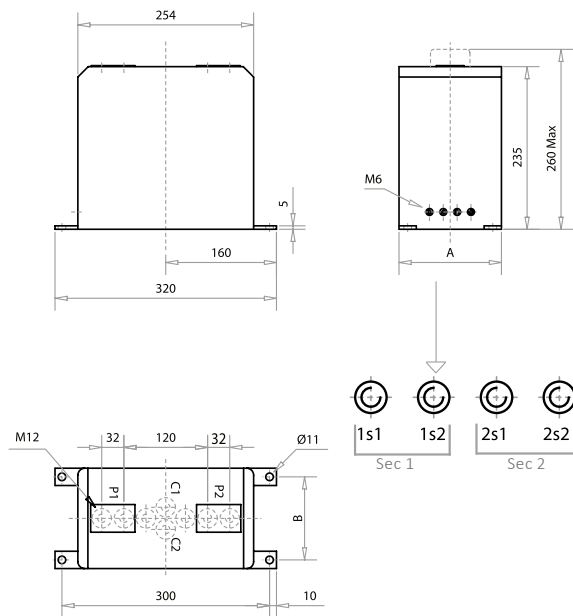

### Without metallic supports

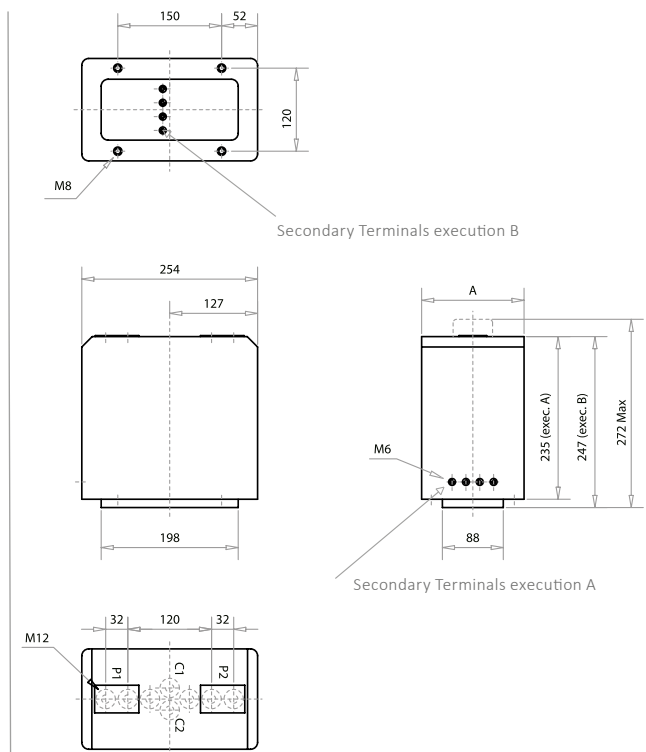

AM11



AM22

Type	Ip Max [A]	Max. N° sec.	Dimensions [mm]		Weight [kg]
			A	B	
AM11	1250	3	148	120	~18
AM22	1250	3	198	160	~15

# DIN CT

## General Characteristics

### General Characteristics

- Dimensions according to DIN 42600-8 std.
- Manufactured and tested acc. to IEC 61869-1/2
- Rated Insulation level up to 24 kV
- Frequency 50 or 60 Hz
- Rated primary current (I<sub>pr</sub>)
  - Single primary current from 5 to 2500 A
  - Double primary current
    - Up to 2 x 300 A change on prim. winding
    - Up to 2 x 1250 A change on sec. winding
- Rated secondary current (I<sub>sr</sub>) 5 A
- Short-time current (I<sub>th</sub>) up to 40 kA x 1s
- Rated dynamic current (I<sub>dyn</sub>) 2.5 x I<sub>th</sub>
- Number of secondary 1 or 2

- Security factor  $\leq 5$  or  $\leq 10$
- Indoor installation
- Sec. terminal board acc. to DIN
- Accuracy class for measure: 0,5 - 0,5s - 0,2 - 0,2s
- Accuracy class for protection: 5P10 - 5P20 - 5P30

### On Request

- Third secondary
- Rated secondary current 1A
- Capacitive tap
- Execution with wings
- Standard sec. terminal board

### Primary Terminals

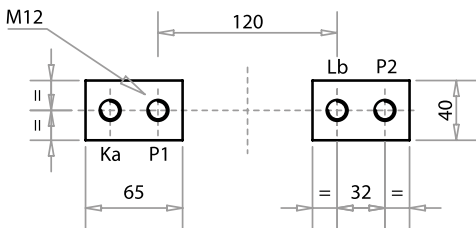

5 - 1500 A

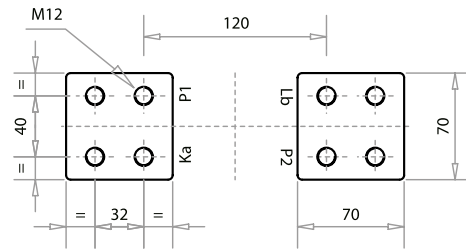

5 - 2500 A

### Double Primary Current

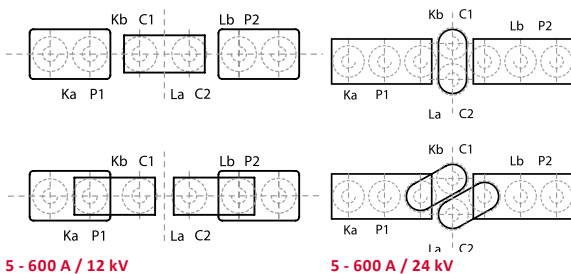

5 - 600 A / 12 kV

5 - 600 A / 24 kV

### Low Ratio

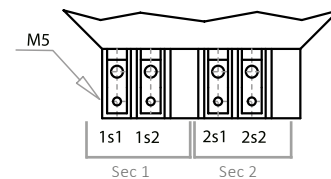

### High Ratio

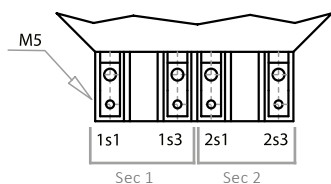

800 - 2500 A

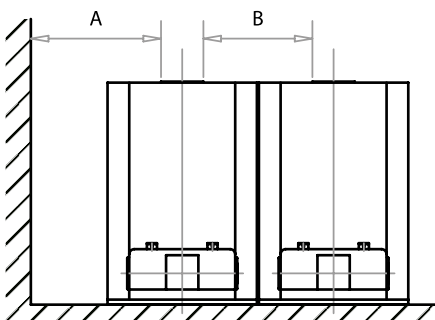

Minimum suggested assembly distances

	12 kV	24 kV
A [mm]	120	220
B [mm]	120	220

According to IEC / CEI EN 6007-1

# 12 kV

## Overall Dimensions

Sec. Terminal board acc. to DIN

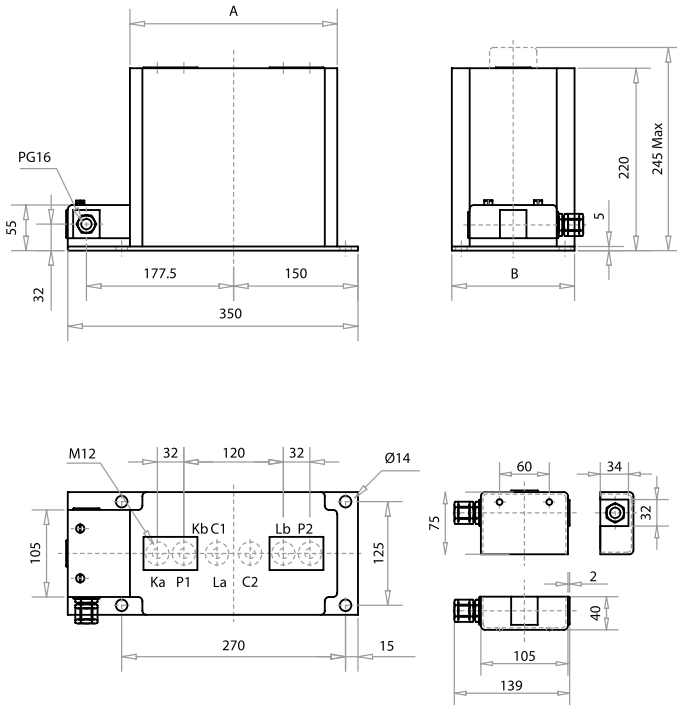

Standard Sec. Terminal Board

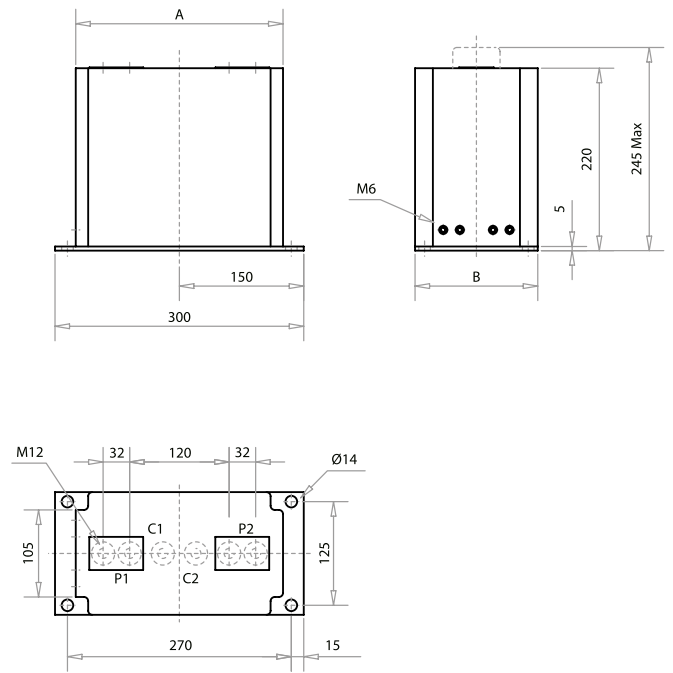

Standard execution



Execution with wings



AD01

Type	Ip Max [A]	Max. N° sec.	Dimensions [mm]		Weight [kg]
			A	B	
AD01	2500	3	250	148	~18

# 24 kV

## Overall Dimensions

Sec. Terminal board acc. to DIN

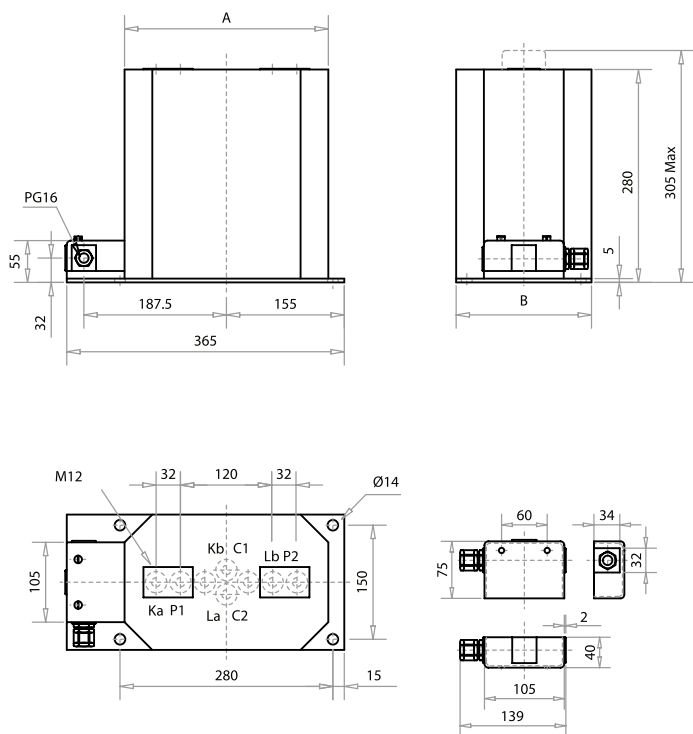

Standard Sec. Terminal Board

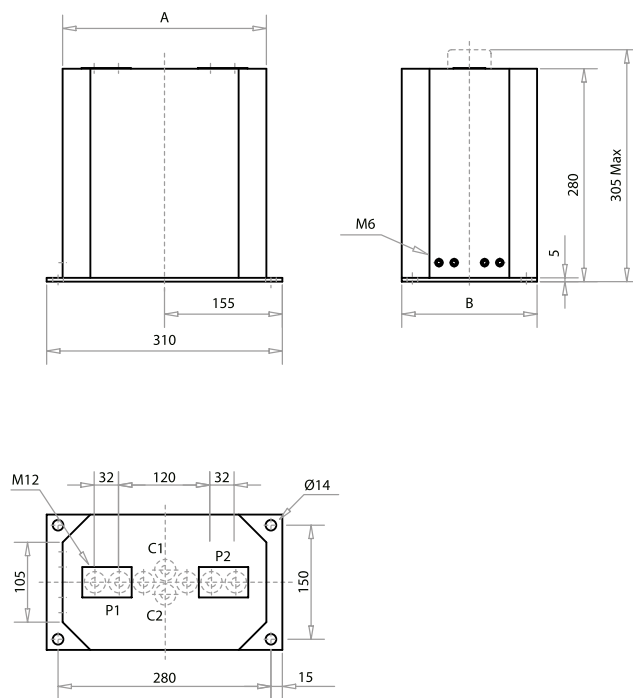

Standard execution



Execution with wings



AD11

Type	I <sub>p</sub> Max [A]	Max. N° sec.	Dimensions [mm]		Weight [kg]
			A	B	
AD11	2500	3	270	178	~25



# Ring Current CT

## General Characteristics

### General Characteristics

- Manufactured and tested acc. to IEC 61869-1/2
- Rated Insulation level 0,72 kV
- Frequency 50 or 60 Hz
- Rated primary current ( $I_{pr}$ )  
Single primary current from 50 to 20.000 A
- Rated secondary current ( $I_{sr}$ ) 5 A
- Short-time current ( $I_{th}$ ) up to 40 kA x 1s
- Rated dynamic current ( $I_{dyn}$ ) 2.5 x  $I_{th}$
- Number of secondary 1
- Security factor  $\leq 5$  or  $\leq 10$
- Indoor installation
- Accuracy class for measure: 0,5 - 0,5s - 0,2 - 0,2s
- Accuracy class for protection: 5P10 - 5P20 - 5P30

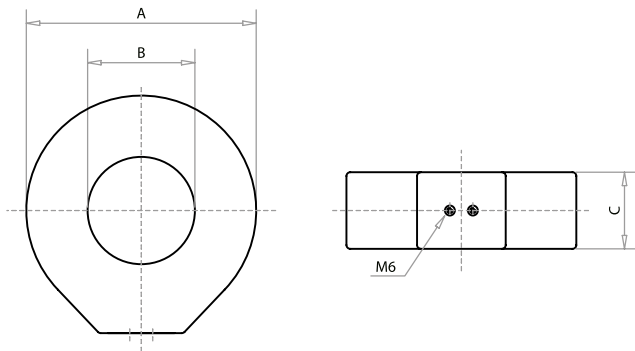

R180



R323

### On Request

- Second secondary
- Rated secondary current 1A
- Terminal cover
- outdoor installation
- ATEX certification

Type	Dimensions [mm]		
	A	B	C
R055	200	55	115
R100	250	100	95
R105	190	105	70
R106	270	105	70
R107	240	105	70
R140	240	140	80
R141	300	140	80
R142	300	140	100
R180	400	180	130
R181	400	180	130
R182	400	180	150
R183	400	180	190
R320	640	320	65
R322	500	320	92
R323	500	320	120
R350	635	350	122
R351	620	350	120
R400	590	400	113

# CEI - UNEL Phase to Phase VT

## General Characteristics

### General Characteristics

- Dimensions according to CEI-UNEL 21008 std.
- Manufactured and tested acc. to IEC 61869-1/3
- Rated Insulation level up to 36 kV
- Frequency 50 or 60 Hz
- Rated voltage factor 1,2 continuous
- Number of secondary 1
- Rated secondary voltage 100 V
- Indoor installation
- Accuracy class for measure: 0,5 - 0,2
- Accuracy class for protection: 3P-6P

### On Request

- Second secondary
- Double primary ratio
- Sealable terminal cover
- Rated secondary voltage 110 V

### Primary Terminals



### Double Primary Voltage

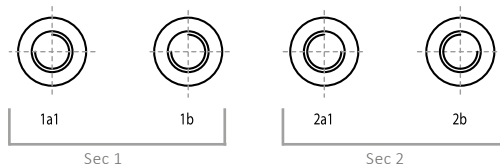

Low Ratio

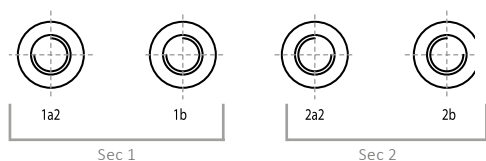

High Ratio

# 12 kV / 24 kV / 36 kV

## Overall Dimensions

CA11 - CB11

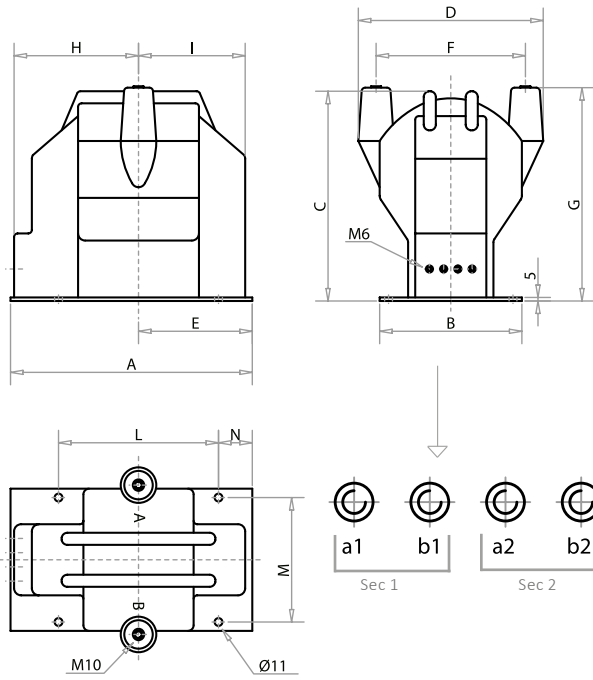

CC11

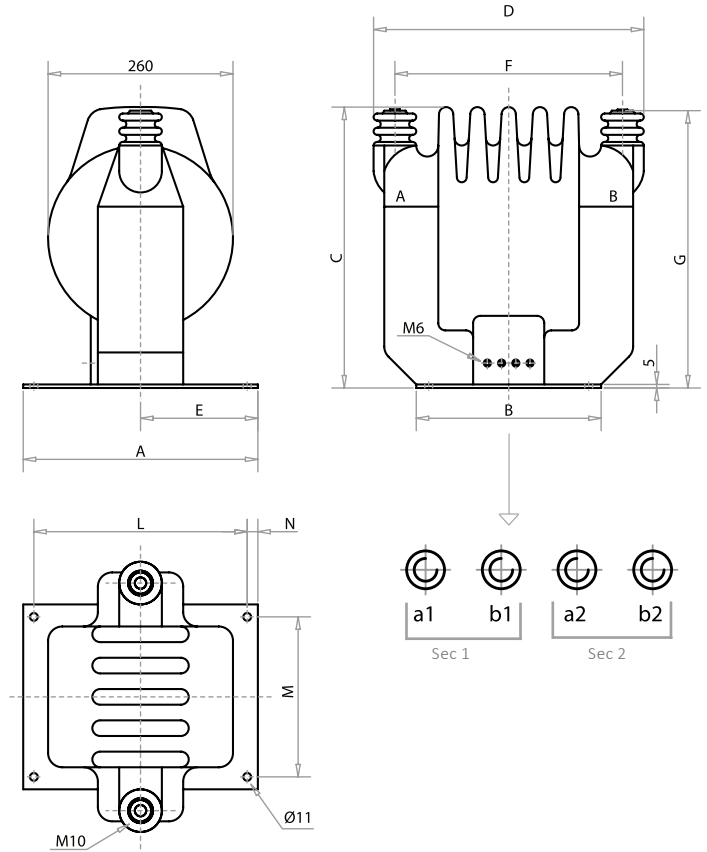

CA11

CB11

CC11

Type	Upr [kV]	Max. N° sec.	Dimensions [mm]												Weight [kg]
			A	B	C	D	E	F	G	H	I	L	M	N	
CA11	≤12	2	305	180	240	195	145	155	225	143	137.5	155	155	67.5	~20
CB11	≤24	2	340	200	295	260	160	210	300	175	150	225	175	47.5	~30
CC11	≤36	2	330	260	395	380	165	320	390	-	-	300	225	15	~50

# CEI - UNEL Phase to Ground VT

## General Characteristics

### General Characteristics

- Dimensions according to CEI-UNEL 21007 std.
- Manufactured and tested acc. to IEC 61869-1/3
- Rated Insulation level up to 36 kV
- Frequency 50 or 60 Hz
- Rated voltage factor 1,2 continuous and 1,9/8h
- Number of secondaries 2
- Rated secondary voltage:
  - Measuring or protective winding: 100:√3 V
  - Residual voltage winding: 100:3 V
- Indoor installation
- Accuracy class for measure: 0,5 - 0,2
- Accuracy class for protection: 3P-6P

### On Request

- Third secondary
- Double primary ratio
- Sealable terminal cover
- Rated secondary voltage: 110:√3 V - 110:3 V

### Primary Terminals

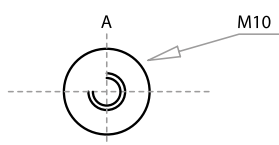

### Double Primary Voltage

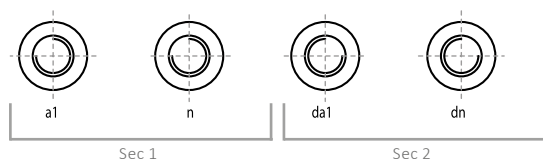

Low Ratio

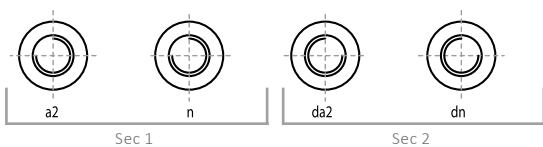

High Ratio

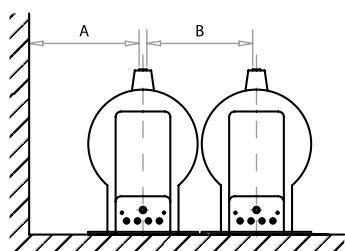

Minimum suggested assembly

	12 kV	24 kV	36 kV
A [mm]	120	220	320
B [mm]	120	220	320

According to IEC / CEI EN 6007-1

# 12 kV / 24 kV / 36 kV

## Overall Dimensions

FA11 - FB11

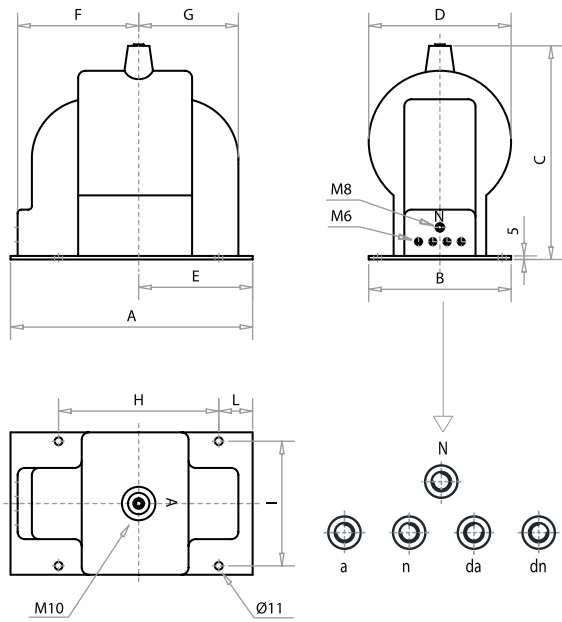

FC11

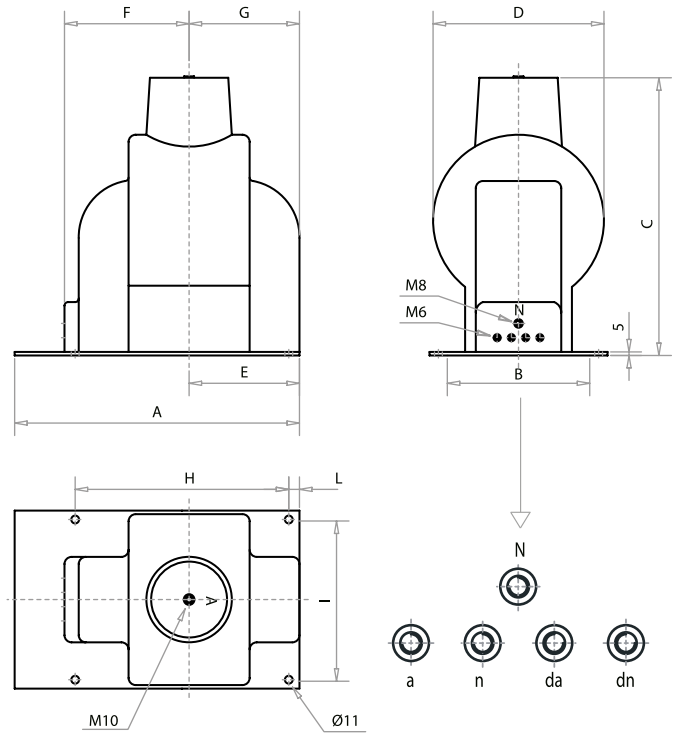

FA11

FB11

FC11

Type	Upr [kV]	Max. N° sec.	Dimensions [mm]										Weight [kg]
			A	B	C	D	E	F	G	H	I	L	
FA11	≤12 : V3	3	305	180	240	180	145	150	130	155	155	67.5	~22
FB11	≤24 : V3	3	340	200	300	200	160	170	140	225	175	47.5	~30
FC11	≤36 : V3	3	400	250	390	240	155	175	155	300	225	15	~40

# DIN Phase to Phase VT

## General Characteristics

### General Characteristics

- Dimensions according to DIN 42600-9 std.
- Manufactured and tested acc. to IEC 61869-1/3
- Rated Insulation level up to 24 kV
- Frequency 50 or 60 Hz
- Rated voltage factor 1,2 continuous
- Number of secondary 1
- Rated secondary voltage 100 V
- Indoor installation
- Sec. terminal board acc. to DIN
- Accuracy class for measure: 0,5 - 0,2
- Accuracy class for protection: 3P-6P

### On Request

- Second secondary
- Double primary ratio
- Standard sec. terminal board
- Rated secondary voltage 110 V

### Primary Terminals

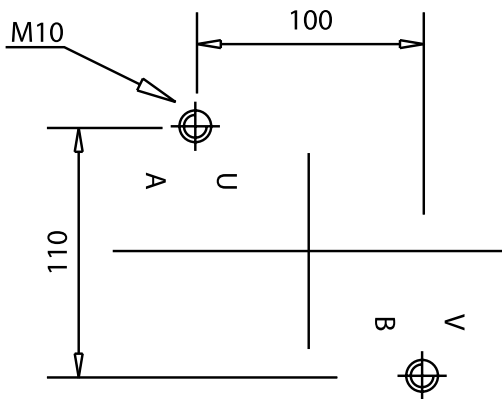

### Double Primary Voltage

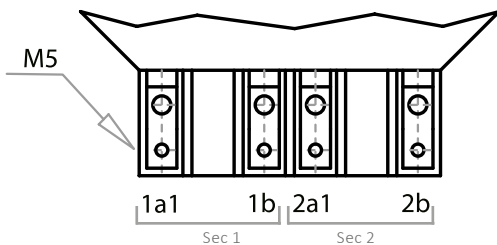

Low Ratio

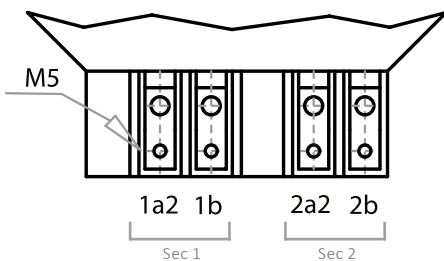

High Ratio



# 12 kV / 24 kV

## Overall Dimensions

Sec. Terminal board acc. to DIN

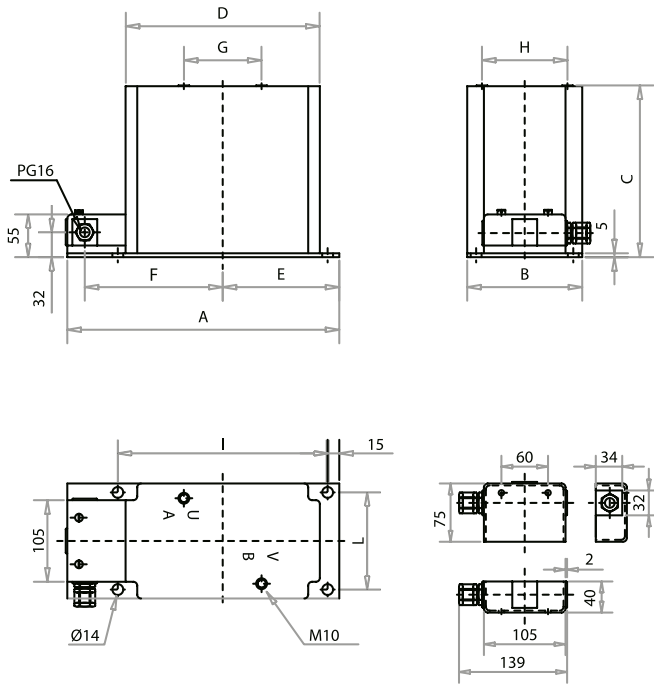

Standard sec. terminal Board

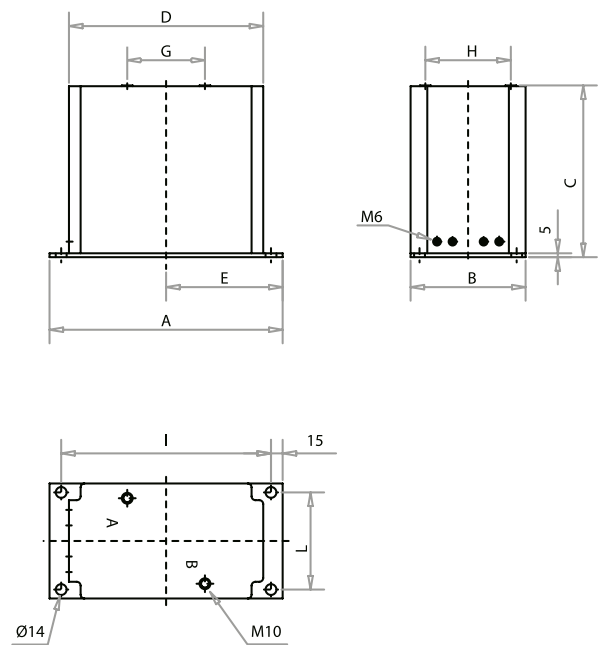

CD01



CD11

Type	Upr [kV]	Max. N° sec.	Dimensions [mm]										Weight [kg]
			A	B	C	D	E	F	G	H	I	L	
CD01	≤12	2	350	148	220	250	150	177.5	100	110	270	125	~22
CD11	≤24	2	365	178	280	270	155	187.5	165	130	280	150	~30

# DIN Phase to Ground VT

## General Characteristics

### General Characteristics

- Dimensions according to DIN 42600-9 std.
- Manufactured and tested acc. to IEC 61869-1/3
- Rated Insulation level up to 24 kV
- Frequency 50 or 60 Hz
- Rated voltage factor 1,2 continuous and 1,9/8h
- Number of secondary 2
- Rated secondary voltage:
  - Measuring or protective winding: 100:√3 V
  - Residual voltage winding: 100:3 V
- Indoor installation
- Sec. terminal board acc. to DIN
- Accuracy class for measure: 0,5 - 0,2
- Accuracy class for protection: 3P-6P

### On Request

- Second secondary
- Double primary ratio
- Standard sec. terminal board
- Rated secondary voltage: 110:√3 V - 110:3 V

### Primary Terminals

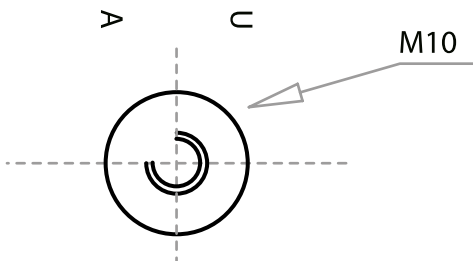

### Double Primary Voltage

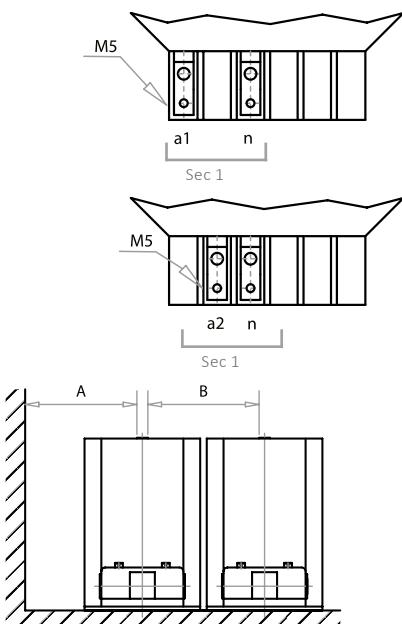

Low Ratio

High Ratio

Minimum suggested assembly distances

	12 kV	24 kV
A [mm]	120	220
B [mm]	120	220

According to IEC / CEI EN 6007-1

# 12 kV / 24 kV

## Overall Dimensions

Sec. Terminal board acc. to DIN

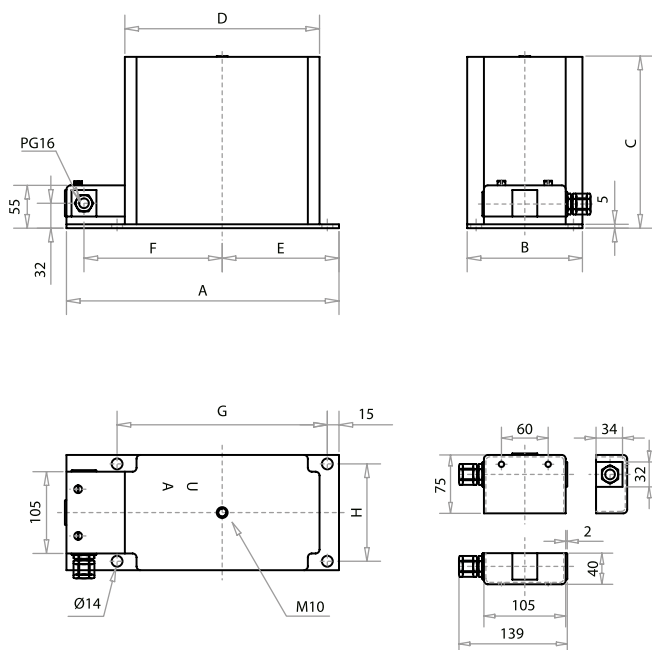

Standard sec. terminal Board

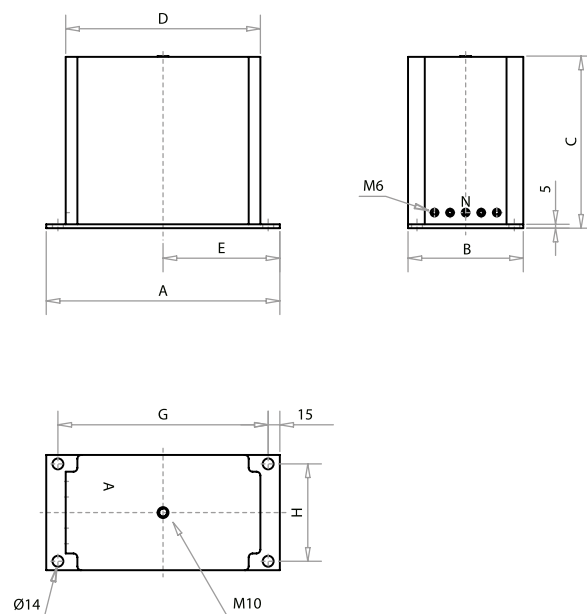

FD01



FD11

Type	Upr [kV]	Max. N° sec.	Dimensions [mm]								Weight [kg]
			A	B	C	D	E	F	G	H	
FD01	≤12 : √3	2	350	148	220	250	150	177.5	270	125	~22
FD11	≤24 : √3	2	365	178	280	270	155	187.5	280	150	~30

# Fuse-Holder Phase to Ground VT

## General Characteristics

### General Characteristics

- Manufactured and tested acc. to IEC 61869-1/3
- Rated Insulation level up to 36 kV
- Frequency 50 or 60 Hz
- Rated voltage factor 1,2 continuous and 1,9/8h
- Number of secondary 2
- Rated secondary voltage:
  - Measuring or protective winding: 100: $\sqrt{3}$  V
  - Residual voltage winding: 100:3 V
- Indoor installation
- Accuracy class for measure: 0,5 - 0,2
- Accuracy class for protection: 3P-6P

### On Request

- Third secondary
- Double primary ratio
- Sealable terminal cover
- Rated secondary voltage: 110: $\sqrt{3}$  V - 110:3 V

### Primary Terminals

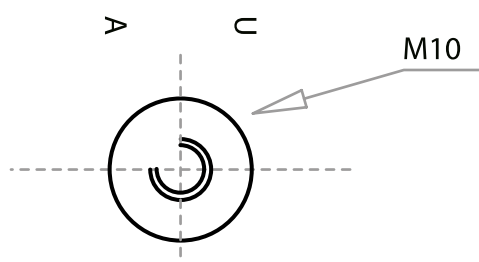

### Double Primary Voltage

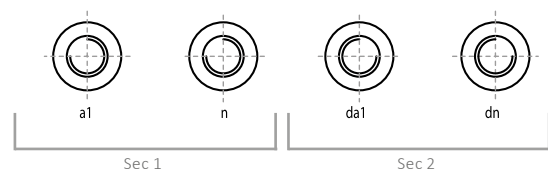

Low Ratio

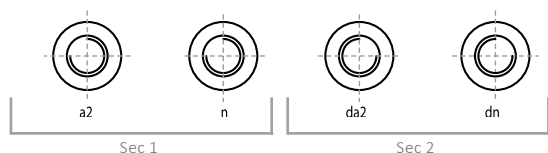

High Ratio

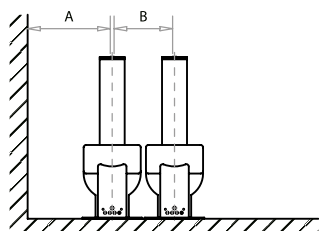

Minimum suggested assembly Distances

	12 kV	24 kV	36 kV
A [mm]	120	220	320
B [mm]	120	220	320

According to IEC / CEI EN 6007-1

# 12 kV / 24 kV / 36 kV

## Overall Dimensions

**FTS1 - FBS1**

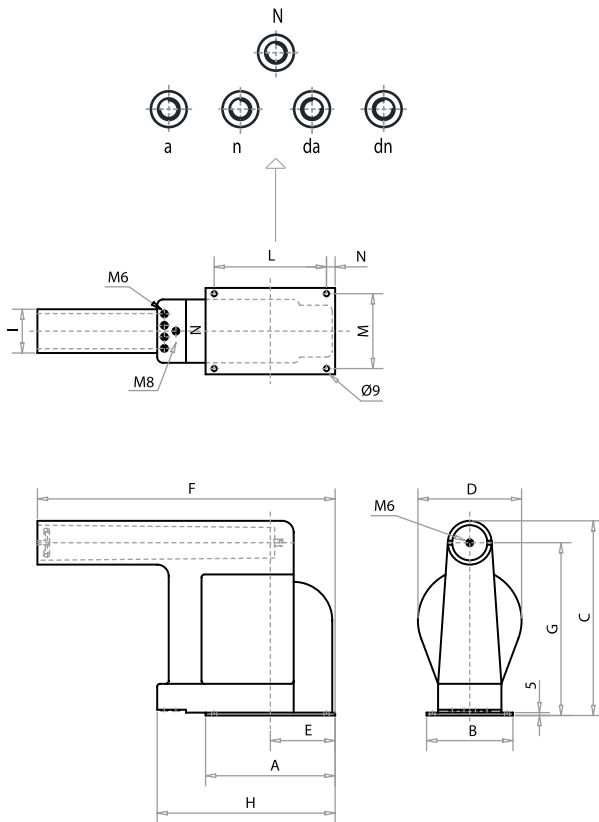

**FCS1**

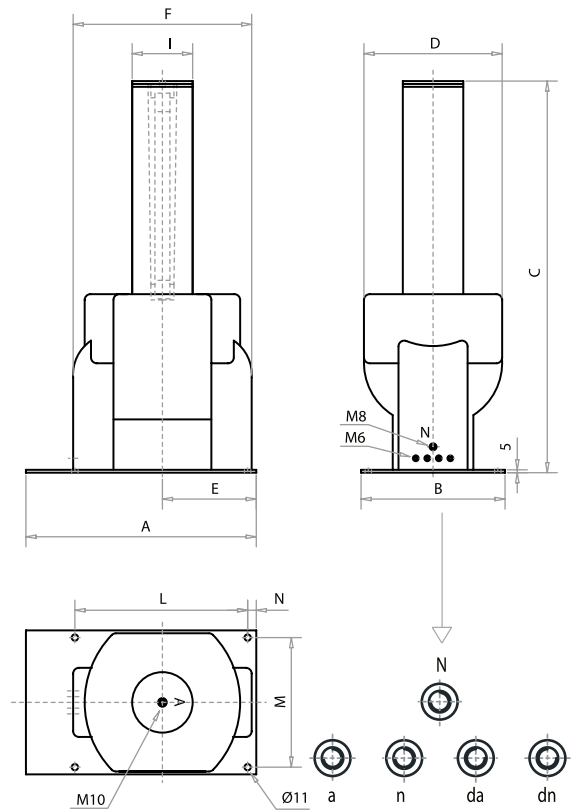

**FTS1**



**FBS1**



**FCS1**

Type	Upr [kV]	Max. N° sec.	Dimensions [mm]												Weight [kg]
			A	B	C	D	E	F	G	H	I	L	M	N	
FTS1	≤17.5 : √3	3	225	150	303	160	112.5	405	265	275	76	195	130	15	~20
FBS1	≤24 : √3	3	225	150	338	180	112.5	517	300	309	76	195	130	15	~28
FCS1	≤36 : √3	3	400	250	680	240	163	240	-	-	105	300	225	15	~40



Instrument Transformers at Laboratory



Storage



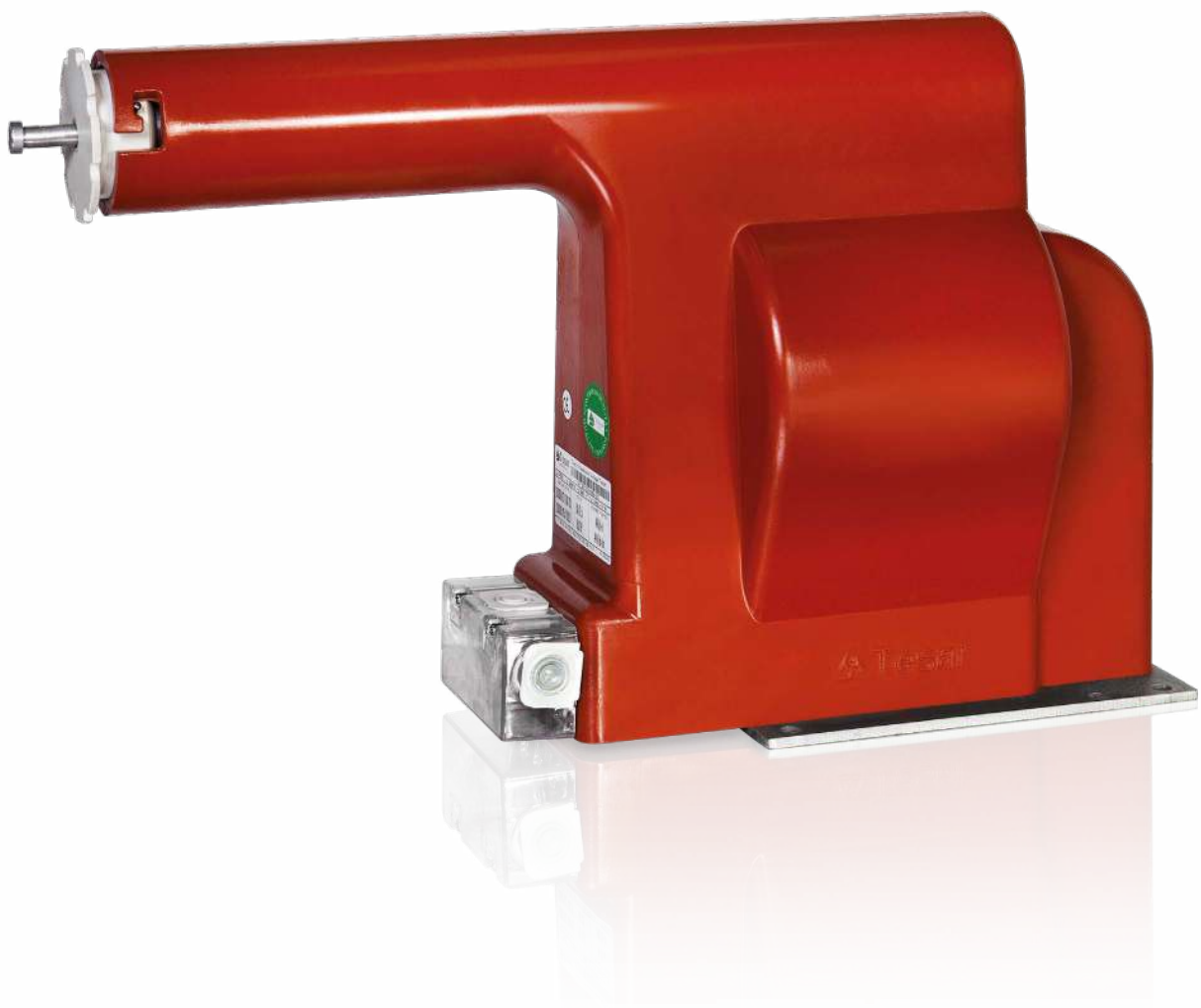

# Companies of R&S

## **R&S International Holding**

Reuslistrasse 32  
4450 Sissach  
Switzerland  
info@the-rsgroup.com  
www.the-rsgroup.com

## **SERW**

Tymákovská 42, Sedlec  
332 02 Starý Plzenec  
Czech Republic  
serw@serw.cz  
www.serw.cz

## **Tesar**

Loc. Chiaveretto  
52010 Subbiano - Arezzo  
Italy  
info@tesar.eu  
www.tesar.eu

## **Rauscher & Stoecklin**

Reuslistrasse 32  
4450 Sissach  
Switzerland  
info@raustoc.ch  
www.raustoc.ch

## **ZREW Transformers**

ul. Rokicińska 144  
92-412 Łódź  
Polen  
transformatory@zrew-tr.pl  
www.zrew-transformatory.pl

## **Tesar Polska**

ul. Skarbowa 34  
32-005 Niepołomice  
Polen  
info@tesarpolska.pl  
www.tesarpolska.pl

---

## **Tesar S.r.l.**

Località Chiaveretto 37 / B,  
IT-52010 Subbiano - Arezzo

T +39 0575 3171  
F +39 0575 317201

info@tesar.eu  
www.tesar.eu